

# electronic devices

K

MINIBUS™ DIGITAL DATABUS SYSTEM	K1
TIMER/DIMMER MODULES	K2
DAYTIME RUNNING MODULE	K3
TAILLITE CONVERTER MODULE	K4

## electronic devices

### K1 MINIBUS™ DIGITAL DATABUS SYSTEM

#### MiniBus™ Digital Databus System

*Controls and monitors electrical motors and lighting using very low currents.*

Modular scalable system.

Replaces conventional power distribution panels, and eliminates the need for complex and expensive wiring harnesses, and simplifies equipment wiring.

Connects as many as 128 switch functions to high-current devices.

#### System components

- 48408 Power Distribution Module (PDM)
- 48450 Switch Interface Module (SIM)
- 58500 Configurable Digital Rocker Switch
- 12800 Cable Assembly (Digital Rocker to SIM)
- 12801 Data Cable Assembly (SIM to PDM)
- 40225 Audible Alarm
- 48800 Series of Timer Modules. *See Section K2*
- 48850 MiniBus Applications Programming Kit

Digital switches feed commands to the SIM unit, which in turn communicates the instructions to the PDM unit via a dual twisted pair cable. The PDM filters the command messages and routes them to the appropriate target load, turning each load on or off (or to preset levels). The system continuously monitors each load and relays operational status information back to the switches (indicated by the switch pilot lights).

#### System Features

**System capacity:** 128 discrete switching channels, utilizing 16 daisy-chained PDM units (8 outputs each) and 8 SIM units (16 inputs each).

**Power outputs:** PDM units have 8 outputs. Each output can source up to 20A (maximum 100A per PDM).

**Overcurrent protection:** Each PDM output is protected by an electronic circuit breaker that can be programmed to any of eight trip currents from 2A to 20A. Breakers are manually resettable by shutting the digital switch Off and On at the remote control.

**Power output terminals:** Standard 0.25" blade terminals on the PDM are angled to facilitate ease of wiring.

**Software:** Graphical user interface is intuitive and easy to use.

**Switches:** Conventional rocker switch appearance. Switches can be programmed to any function - maintained/momentary; independent/independent illumination; latched or toggled.

**Switch Pilot Lights:** LED pilot lights are true indicators that the entire system is functioning in real-time. Compare with standard DC switches that merely confirm a circuit is drawing current.

**True remote station control:** Each output can be controlled seamlessly from any number of auxiliary control stations.

CONTINUED **K1**

### System Technical Specifications

**Rated Input Voltage,  $V_{IN}$  for 12V or 24V**  
9.0V DC min to 32V DC max. Suitable for use with 12V or 24V electrical systems.

**Operating Quiescent Current  $I_Q$  with outputs Off ( $V_{IN} = 14.0V$  DC)**  
0.030 – 0.035A (30-35mA) typical for a basic system of one PDM and one SIM.  
 $I_Q$  PDM of 20 – 25mA typical per PDM.  
 $I_Q$  SIM of 8 – 10mA typical per SIM.

**Digital Data Communications Protocol**  
RS-485 serial databus, half duplex.  
Custom proprietary software.  
Compatible with Faria® Helmsman™ subnetwork serial databus.

**Compliance**  
The MiniBus™ Digital DataBus Systems is designed to comply with applicable sections of the following specific industry standards:

ABYC Standard E-11 (formerly E-9) for overcurrent protection and ignition protection. System has trip-free type circuit breaker with manual remote reset (non-contacting interrupt mechanism).

USCG Title 33 Code of Federal Regulations, Section 183.455(a) for overcurrent protection.

CE for RFI/EMI compatibility.

UL certification for compliance with published specifications.

NFPA for materials flammability.

**SAE standards:**

SAE J1171 for ignition protection.

SAE J1455

- 4.1 for temperature storage and operating (-40° to +85°C)
- 4.2 for humidity (98% at 38°C)
- 4.3 for salt spray atmosphere (5% salt in aqueous solution atomized at 35°C for 24 hours.)
- 4.4 for immersion and splash (water, chemicals and oils).
- 4.9 for mechanical vibration (swept sine method 4.9.4.12, reference Figure 6).
- 4.10 for mechanical shock (operational shock 10G peak).
- 4.11 for electrical environment (see PDM specifications).

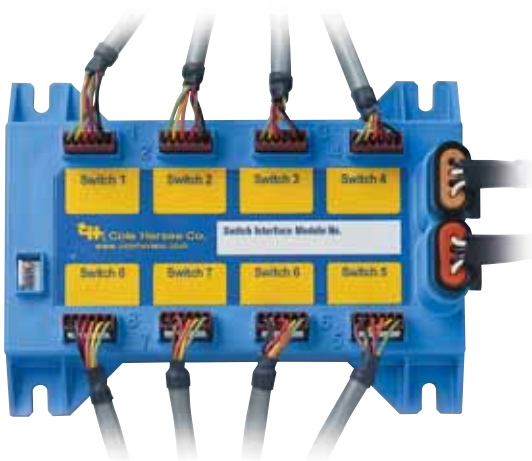

#### Standard Cables and Connectors

Interconnect between PDM and SIM with dual shielded twisted pair cable with Delphi (Packard) 12162188 sealed connectors (with 12103881 terminals) at each end. One twisted pair carries data communications, the other provides power from PDMs to the SIMs.

Maximum cable length  
(total length of all interconnect cables = 100ft or less (30m).

Digital switch to SIM interconnect via 6-wire ribbon cable with Molex 22-01-2067 connectors (gold-plated contacts) at each end.

#### Materials

**PDM and SIM housings:** Injection-molded Valox 357, flame retardant to UL94-V0 standards.

**Hardware:** Non-ferrous with galvanic series compatibility.

#### Installation requirements

Complete reference manual is on the CD that is part of the programming kit. It includes installation instructions, software instructions, and system design guidelines.

#### Troubleshooting, error codes & diagnostics

A system of flashing LEDs in the digital switches, and an audible alarm (if installed), readily characterize the nature of the different error states:

- Overcurrent or short-circuit condition at any output
- Communication failure
- Thermal shutdown
- **Internal self-diagnostics**  
The PDM imbedded software includes various self-diagnostic routines to monitor the system performance.
- **Redundant output protection**  
Multiple overcurrent, short circuit and thermal overload protection.

★ Rapid ship item. BP Available in retail clamshell pack. ★ Minimum order quantity may apply.

## 48408 Power Distribution Module (PDM)



### Input voltage (power source)

- 12V DC or 24V DC
- Steady state electrical characteristics are per SAE J1455 4.11.1.1 for nominal, minimum and maximum voltage.
- Start voltage (CCA) 7.5V DC minimum at PDM.

### Power input protection

- Transient protection: Load dump and inductive switching per SAE J1455 4.11.2 tables 4A and 4B.
- Each PDM must be protected by an external overcurrent device between the power source and the PDM. Overcurrent device rating must be equal to the sum of the eight internal PDM breaker settings (100A maximum). Power line from the power source to the PDM should include a master disconnect switch or battery switch. Such wiring is mandated for marine installations per ABYC Standard E-11 (formerly E-9), and associated USCG requirements.
- The power input studs on the PDM are sized differently in compliance with standard industry practice to obviate incorrect wiring at installation.

### Ratings

- Output voltage  $\geq V_{in}$ : 0.25V at  $I_{out} = 20A$  at 25°C. Input-output drop is  $\leq 150$  MV typical at 20A, 25°C.
- Output current: 20A maximum, continuous.
- Instantaneous surge current (inrush): 35A maximum, decreasing to  $\leq 20A$  within 300ms.
- Internal circuit-derived short-circuit protection (typical)  $\approx 95A$  at 12V, 70A at 18V, 46A at 24V. Trip within 2ms.
- Internal hardware-derived short-circuit protection (typical) 30A/1.0s, 70A/0.3s, 110A/0.1s at 25°C.
- Output protection: Protected against inductive load switch-off energy (load dump) up to 400mJ (0.4Ws). Additional output negative transient protection is provided up to -600V (3A continuous, 100A peak, one 8ms half-sine pulse).

## Electronic circuit breaker

- Action: Manually resettable after break, utilizing remote switches (complies with ABYC and USCG manually resettable overcurrent protection requirement).
- Rated breaker trip currents are programmable to 2.0, 3.0, 4.0, 5.0, 7.5, 10.0, 15.0, or 20A. Breakers carry rated current indefinitely. Trip action is controlled by slow blow timing and by software algorithm which simulates conventional thermal-mechanical breaker performance.
- Outputs are rated for resistive and reactive loads, and incandescent lighting current surges.
- Overcurrent protection redundancy: 5 levels. Two software-derived, two circuit-derived, one hardware-derived.

## 48450 Switch Interface Module (SIM)



Data: RS-485 circuit interface.

Power: 7.0V – 9.0 V DC nominal, 6.0V – 16.0V DC range.

Switch input requirements: input is grounding, with hard pull-up resistance (internal to the SIM, 39K $\Omega$  typical) to 5.0V DC nominal circuit B+. Typical switch current 100-150 $\mu$ A.

LED output: 5.0V DC for LED On. LED current not to exceed 20mA (external current limiting).

## 12800 Cable Assembly (Digital Rocker to SIM)

### 12801 Data Cable Assembly (SIM to PDM)

Connectors: Delphi (Packard) style molded-in 4-pin panel mounted header. Interfaces with Delphi (Packard) 12162188 connector.

Data: RS-485 circuit interface.

Power: 7.5V DC nominal. Sourcing current: 3.0A.

### 40225 Audible Alarm

Optional alarm to signal 'no load' or 'overcurrent'. Connector fits SIM 48450.

### 48800 Series of Timer Modules

See Section K2

## 48850 MiniBus Applications Programming Kit

★ Rapid ship item. BP Available in retail clamshell pack. ★ Minimum order quantity may apply.

Three general purpose timer/dimmer modules, plus Marine Foghorn Timer. These items have many applications for controlling motors or lighting. Cole Hersee can build a custom unit to your special order – call us.

Modules (except the Foghorn Timer) each have one-time preset options – the user selects an option by selectively cutting the jumper wires. Modules consist of a microprocessor-based timer driving a solid state solenoid type output. The actuator for the timer can either be a manual or an automatic switch.

Modules are particularly appropriate for certain marine and RV applications: operating lighting, horns, pumps, or blowers.

### Series 48800



**Wiring:** 2 power in, 2 power out, control wire to momentary switch. Instructions are included. Power wires 16AWG control wires 18AWG, loops 22AWG. System voltage 12V DC (9-16V).

**Solid state:** Handles up to 20A peak load – enough to power incandescent lights, motors, or other inductive or reactive loads.

**Reliable:** no moving parts. Cool-running. Use with either incandescent or LED lighting.

**Rugged, weatherproof, vaporproof:** Strong plastic molded case, potted for added durability and protection.

**Integral protection:** Incorporates an electronic circuit breaker which provides another level of protection from overload. Includes a thermal overload shutdown circuit. Breaker can be reset by activating the control switch. The module is also protected against reverse polarity.

Use with conventional switches, or digital signal switches. Can be used with any low current single pole normally open momentary switch (push button, rocker, toggle, rotary etc.)

**Simple installation:** Case is small and readily screwed or bolted in place.

**Case size:** 1.356"H (not including flange) x 1.97"W x 1.03"D (34.4mm x 49.9 x 26.2mm). Flange is 0.32"H x 1.97"W (7.94 x 49.9mm). 3 mounting holes: .28" diameter (7.2mm), 0.56" (14.3mm) on centers.

#### \*48810-01 Delay Timer BP

Suitable for controlling exhaust fans and blowers, or boat courtesy lights.

Selectable preset options:  
 Option 1: 2 minutes delay  
 Option 2: 4 minutes delay  
 Option 3: 6 minutes delay  
 Option 4: 8 minutes delay

#### 48811-01 Stepping Dimmer BP

Suitable for control of truck cab or marine cabin lights. Repeated actuation of the control switch cycles the dimming modes. Holding the momentary switch for 3 seconds turns the lights off, without having to pass through dimming stages.

Selectable preset options:

Option 1: On – Dim 1 – Dim 2 – Dim 3 – Dim 4 – Off  
 Option 2: On – Dim 1 – Dim 2 – Dim 3 – Off  
 Option 3: On – Dim 1 – Dim 2 – Off  
 Option 4: On – Dim – Off

#### 48812-01 Intermittent Timer BP

Suitable for boat bait well pumps and many other applications where intermittent switching is needed.

Selectable preset options:

Option 1: On 2 minutes – Off 1 minute  
 Option 2: On 2 minutes – Off 2 minutes  
 Option 3: On 2 minutes – Off 4 minutes  
 Option 4: On 2 minutes – Off 6 minutes

#### 48813-01 Marine Foghorn Timer BP

On – Both Off – Foghorn timer On  
 On 4 seconds – Off 100-120 seconds

No user-selectable preset options. (The Off period is designed to vary randomly in order to avoid synchronization with foghorn blasts from other vessels.) The timing pattern is recommended by USCG International Navigation Rules (COLREGS) Part D – Sound and Light Signals:

*Rule 35 - Sound Signals in Restricted Visibility (a) Power-driven vessel making way through the water shall sound at intervals of not more than 2 minutes one prolonged blast.*  
*Rule 32 – Definitions (c) The term "prolonged blast" means a blast of from four to six seconds' duration.*

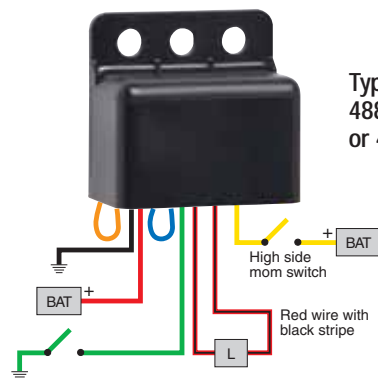

Typical wiring for 48810-01, 48811-01 or 48812-01.

## 48600 DRL Module



Automatically turns on low-beam headlights when the ignition is turned on (after a 10 second delay, thus reducing the initial starting load. Activated when the parking brake is released; deactivated when the parking brake is set (with ignition On). Deactivates when high beams are flashed for signaling. Completely solid-state construction. Supplied with 15A mini-fuse ATM98107-15.

Extends the life of the headlights, because (for daytime running) they are powered at 75% of the high-beam intensity. For two or four headlamp systems.

Complies with FMVSS 108 for headlamp intensity. CMVSS-108 and CAN/CSA D-603-88, type 2. Six 28" (711mm) long wire leads, six 30223 Quick Tap wire splicers (see Section P5), and two self-tapping mounting screws.

Also available without splicers and screws: order part number 48600-01.

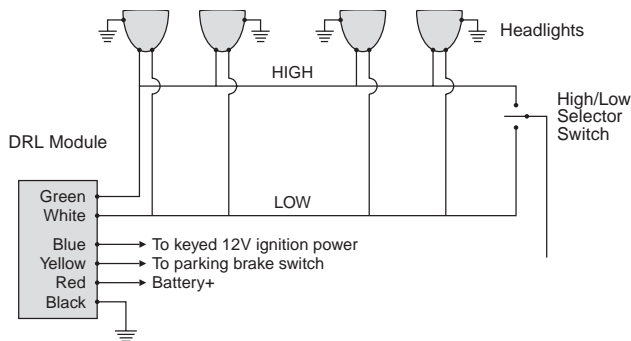

## electronic components

More and more of Cole Hersee components contain electronics – from rotary switches to windshield wiper switches. They possess advantages of being solid state, such as reliability, resistance to adverse weather and vibration. Devices of this type for the most part look like their electro-mechanical counterparts, and you can find them in the appropriate catalog sections: Section E for windshield wiper switches, Section J3 for battery isolators; Section H4 for electronic solenoid, Section N1 for alarm buzzers, and Section D5 for rotary dimmer switches.

Many of the components in this section are 'black boxes' with few external signs to suggest their function. As with all Cole Hersee products, they can be customized to meet other specifications. Call us.

See Section E for windshield wiper switches, Section J3 for battery isolators; Section H4 for electronic solenoid, Section N1 for alarm buzzers, and Section D6 for rotary dimmer switches.



## rotary dimmers

See Section D6 for rotary electronic dimmer switches.



## other electronics

Solid State Alarm: See Section N1

### 48000 Trailer Tail Light Converter



Permits a towing vehicle with two lighting circuits for each side to operate lights on a trailer with a single circuit each side. Eliminates the need to rewire the trailer, or to add additional lights. US laws require stoplights, turn signals and taillights on trailers.

For use with 12V DC negative ground systems only. Using the Converter, towing vehicles with four lighting circuits (left stop, left turn, right stop, right turn) can properly operate trailers with two lighting circuits (left stop and turn, right stop and turn). Solid state circuitry provides high reliability and is embedded, giving complete protection against moisture and vibration. Color-coded 18AWG wire leads are 24" (607.6mm) long for towing vehicle connections, 36" (914.4mm) long for attachment to trailer connector.

Operation of trailer lights is unaffected by a burned-out bulb in the towing vehicle.

Includes wiring and installation instructions, and self-splicing wire connectors for fast installation. Converter has self-adhesive pad for easy mounting inside a trunk, fender wall or other smooth surface.

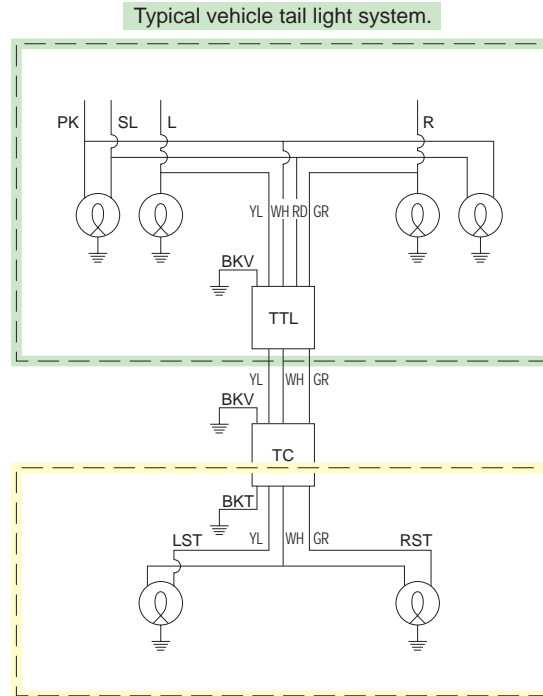

Typical trailer tail light system.  
Trailer ground is not provided.

#### Key to the diagrams

PK	=	Parking lights.
SL	=	Stop lights.
L	=	Left turn signal.
R	=	Right turn signal.
YL	=	Yellow.
WH	=	White.
RD	=	Red.
GR	=	Green.
BKV	=	Black, vehicle ground.
BKT	=	Black, trailer ground.
TTL	=	Trailer tail light module.
TC	=	Trailer connector.
LST	=	Left stop & turn signal light.
RST	=	Right stop & turn signal light.



### other electronics

Battery Isolator Switches: See Section J3



### other electronics

Solid State Solenoid: See Section H4